



# Body-Solid®

Built For Life...Built With A Vision

- **Weight Stations:** 4 independent weight stations.
- **Station Mounts:** 4 universal upper and lower station mounts
- **Pulley Station:** 4 universal upper and lower pulley stations
- **Guide Rod:** 4 easy mount chrome guide rods
- **Options:** 210lb and 310 lb weight stack option
- **Mainframe:** 12 Gauge 2.283×4.567 oval tubing (58 x 116 x 2.5T) on the main frame combined with 3 gauge steel connecting plates and 1/2 diameter connecting bolts provides high strength and durability.
- **Cable:** Spun steel aircraft cables over 2 high density foam, is double stitched and fully supported, guarantee a tear resistant, durable surface for comfort and support.
- **Product Weight:** 378lb / 171.46kg



## DGYMS+DCLP+DPLS+DPEC+DLEC

- DGYMS Base Frame with stacks
- DCLP Leg press / Calf extension
- DPLS Vertical Press and Lat
- DPEC Pec Dec / Rear Delt
- DLEC Leg extension / Leg curl

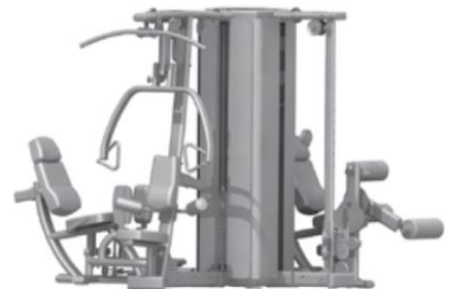
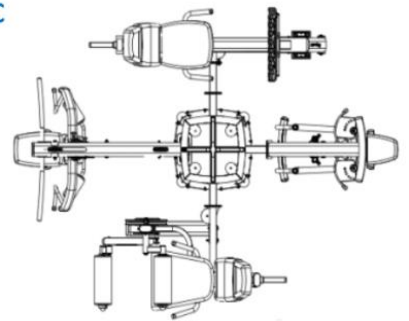

BOSYSOLID

DGYM

DCLP



DPLS

DPEC

DLEC



DCLP



DPLS



DPEC



DLEC



**INTERNATIONAL**  
 3F28, No.5, Shin-Yi road., Sec.5,  
 Taipei, Taiwan  
 Tel : +886-2-27209982  
 Fax : +886-2-2722-9750  
 E-mail : joong@ms13.hinet.net  
 http://www.steelflexfitness.com